

Appendix C

E-SSOD Interface

This document defines the technical interface requirements for a CubeSat to be released from the Epsilon LV using the Epsilon Small Satellite Orbital Deployer (E-SSOD).

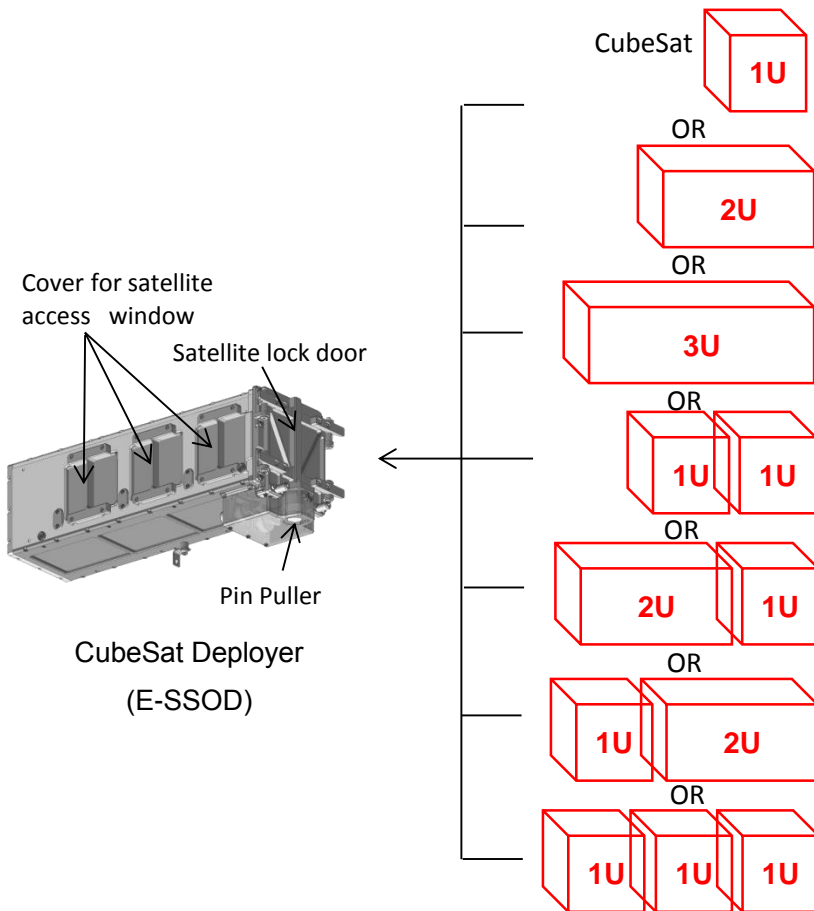

C1. Details of Mounting Position

The definitions of the coordinate systems are shown in Figure C1-1.

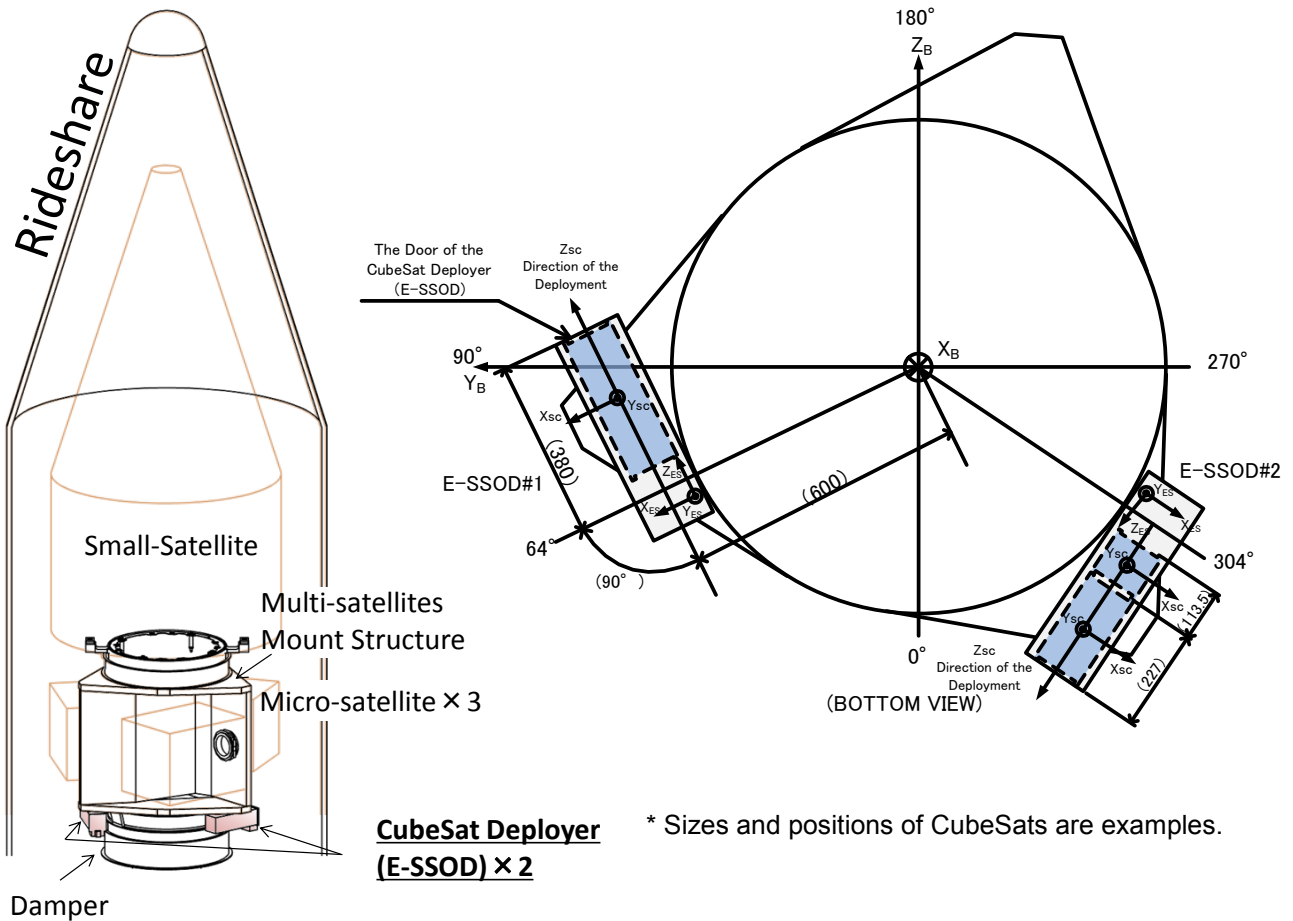
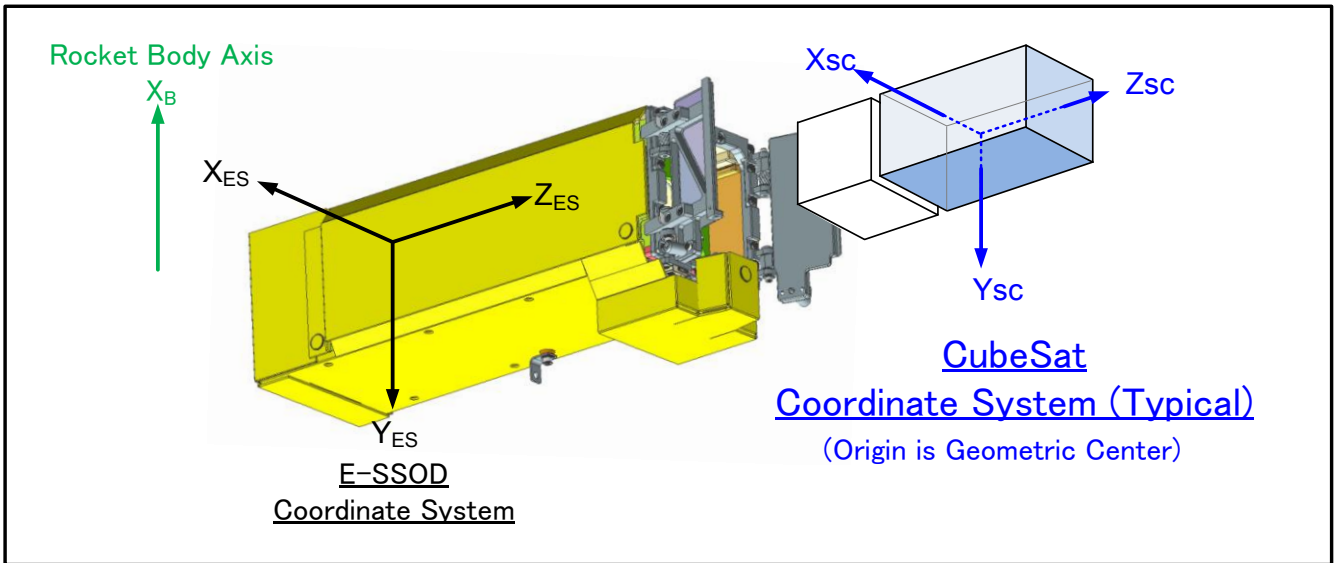

Figure C1-1 Coordinate System Definition

C2. CubeSat Envelope

PL usable volume is defined in Section 4.1.1.

The usable volume of a CubeSat shall meet the requirements in Figure C2-1.

When stored in an E-SSOD, a CubeSat shall hold its deployable components inside its usable volume all by itself and shall not use any structure of the E-SSOD, such as the rail guides and walls, for any purpose.

If there is any possibility that deployable components might be released and then contact the inside walls of the E-SSOD, the possible contact surfaces of such deployable components shall have the thickness of 1 mm or more.

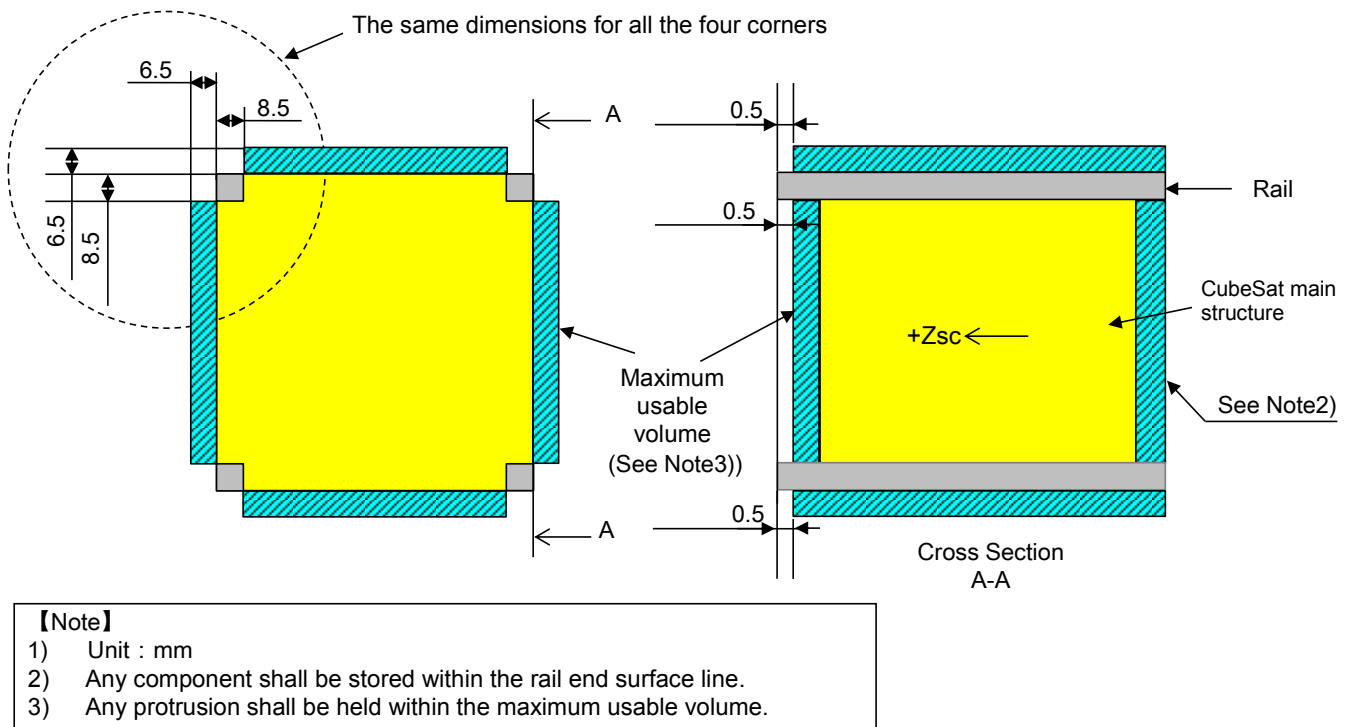

Figure C2-1 Allowable Usable Volume

C3. Mechanical Interface

C3.1 Exterior Dimension Requirements

Allowable sizes of and dimensional requirements for CubeSats are shown in Table C3-1 and Figure C3-1.

Table C3-1 Allowable Sizes of CubeSats

		Exterior Dimensions of PL main structure (including rails)			Rail Dimensions
		Xsc	Ysc	Zsc	
CubeSat	1U	100 ± 0.1 mm	100 ± 0.1 mm	113.5 ± 0.1 mm	at least 8.5 mm square
	2U			227.0 ± 0.1 mm	
	3U			340.5 ± 0.3 mm	

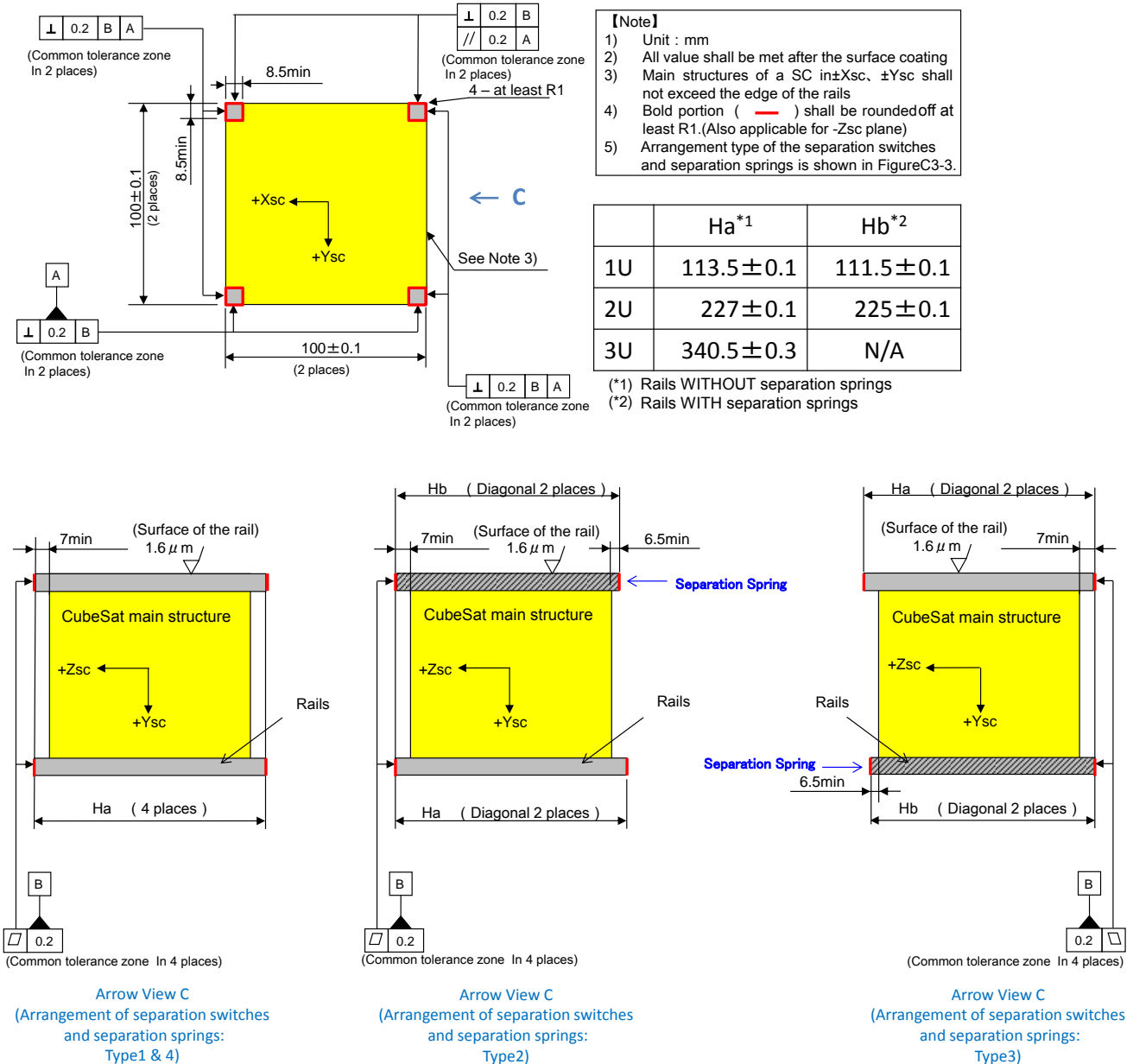

Figure C3-1 Dimensional Requirements for CubeSats

C3.2 Requirements for CubeSat Rails

- (1) A CubeSat shall have four rails on the edges parallel to the Zsc-axis so that it can slide out along the rail guides of an E-SSOD.
- (2) The dimensional requirements are defined in Figure C3-1.
- (3) Each rail shall have a square cross-section of 8.5 mm or more.
- (4) Each rail shall have a surface roughness of Ra 1.6 μm or less.
- (5) Outside edges of a rail shall be rounded off to a radius of at least 1 mm.
- (6) Both rail ends shall have a minimum surface area of 6.5 mm x 6.5 mm.
- (7) Outside surfaces along a rail shall have 75% or more contact area with a rail guide. The remaining 25% or less may have recessed areas from the rail guide. (This means that at least 85.1 mm of a rail shall have the contact area for a 1U CubeSat, at least 170.3 mm for a 2U CubeSat and at least 255.4 mm for a 3U CubeSat.)

Any rail, if devided, shall have its end edges rounded off to a radius of at least 1 mm. The common tolerance zones of such rail surfaces shall satisfy the requirements in both perpendicularity and parallelism specified in Figure C3-1.

Any CubeSat need to be designed to have sufficient structural strength in consideration of compressive load to its body generated at the rail ends.

- (8) All surfaces of rails contacting E-SSOD's rail guides and those of rail ends, or standoffs, contacting adjacent CubeSat standoffs, shall be hard-anodized after machining process. The coating thickness shall be 10 μm or more in accordance with MIL-A-8625, Type 3.

C3.3 Structure Strength

For CubeSats to be stabilized during launch, the gap between the backplate and the back panel of the E-SSOD needs to be adjusted by 4 bolts (see Figure C3-2).

Therefore, each rail shall have a sufficient structural strength in consideration of the maximum preload of 27.9 N applied to four rails in total by the main spring of E-SSOD, and the acceleration to the total mass* of other ridesharing CubeSats in the same E-SSOD and the back plate weighing 0.25 kg (see Figure C3-2).

- * For a 1U CubeSat: 1.5 kg (other CubeSat mass) x 2
- For a 2U CubeSat: 1.5 kg (other CubeSat mass) x 1
- For a 3U CubeSat: 1.5 kg (other CubeSat mass) x 0

The load from the main spring, much smaller than the random vibration load, does not need to be simulated in the vibration test and impact test of PL.

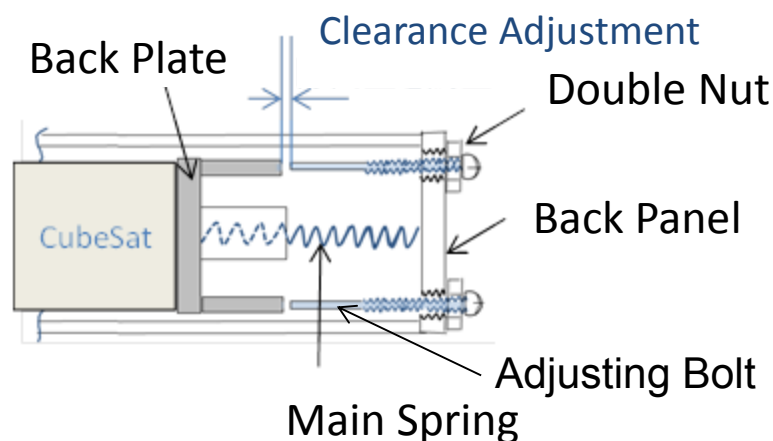

Figure C3-2 Back Plate and Adjusting Bolts of E-SSOD

C3.4 Separation Spring

When a CubeSat is stored with others in a single E-SSOD, such CubeSat is required to have spring plungers (P/N: 251D939002-1) as shown in Figure C3-3 as separation springs to keep enough distance during release from the E-SSOD for collision avoidance; however, a 1U CubeSat of Type 4 as shown in Figure C3-4 and a 3U CubeSat, which is stored alone, does not need any spring plunger. A pair of spring plungers shall be diagonally installed on standoffs, rail ends of a CubeSat, as shown in Figure C3-4.

Figure C3-3 shows the appearance and dimensions of the spring plunger.

Figure C3-4 shows the mounting positions for the spring plunges, whose installation is compulsory, and the allowable positions for the deployment switches (separation switches), whose installation is optional.

Figure C3-5 shows the detailed mounting position of a separation spring (spring plunger)/separation switch (deployment switch) on a standoff.

The flange of a spring plunger shall be firmly attached to the standoff surface as shown in Figure C3-6.

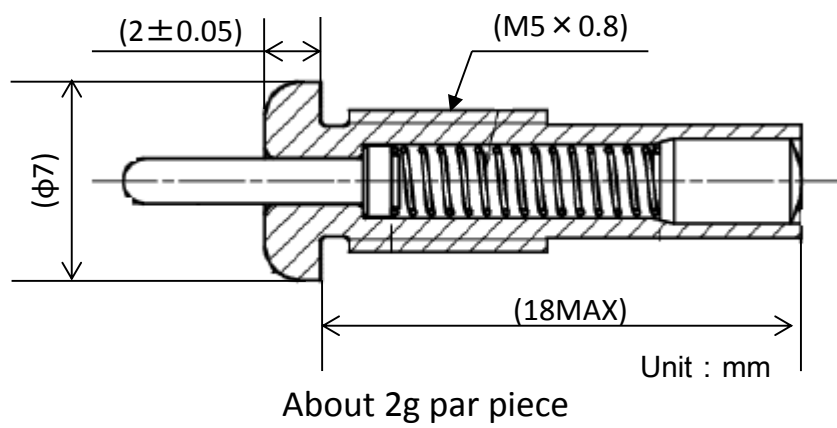
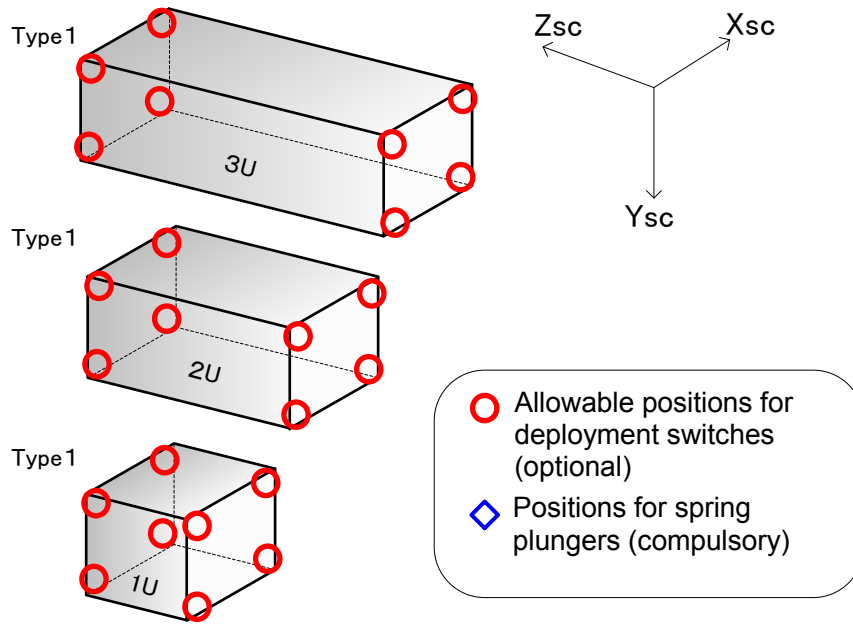
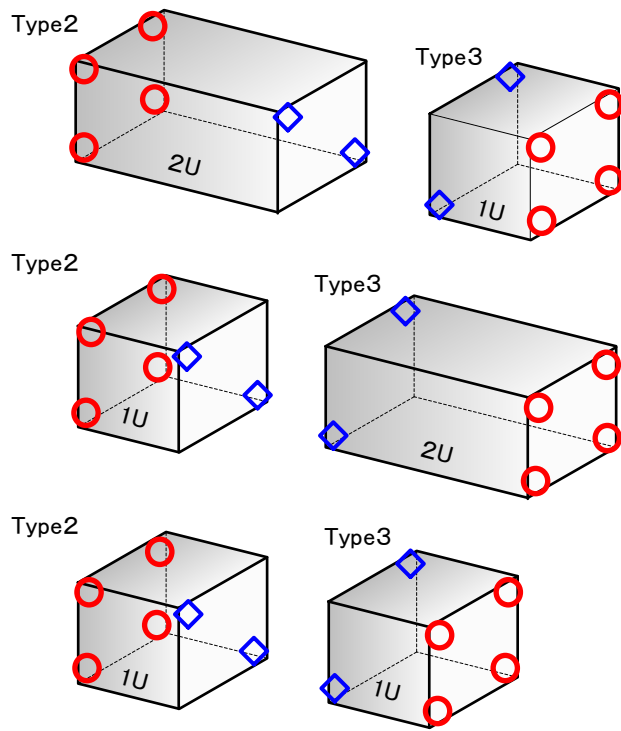

Figure C3-3 Spring Plunger

(1) A single CubeSat stored in an E-SSOD



(2) Two CubeSats stored in an E-SSOD



(3) Three 1U CubeSats stored in an E-SSOD

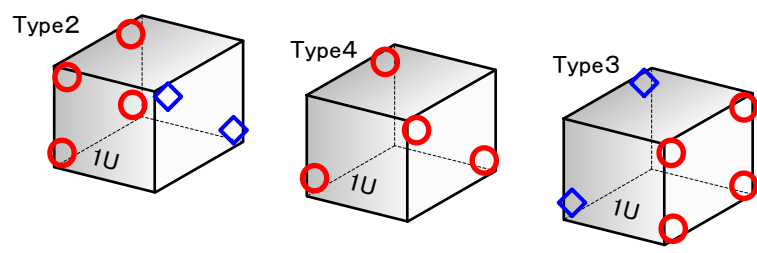

Figure C3-4 Positions of Spring Plungers and Deployment Switches

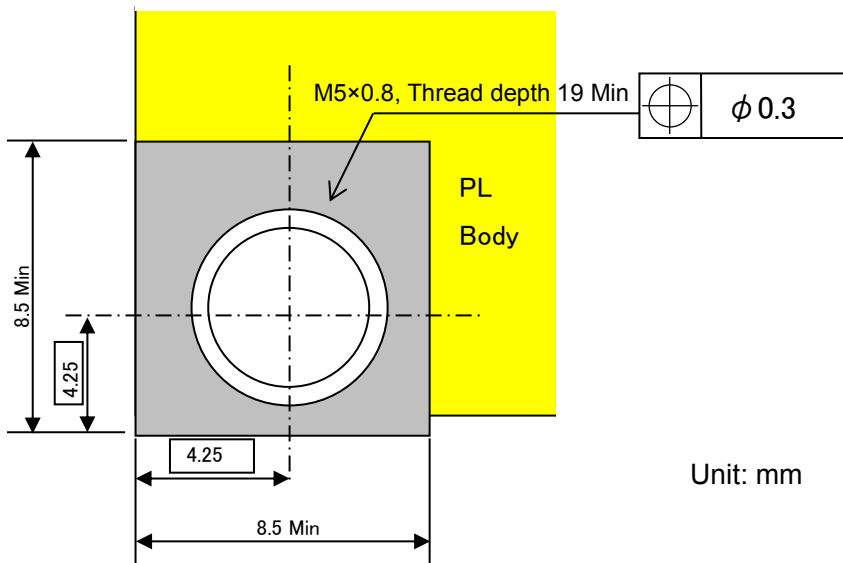
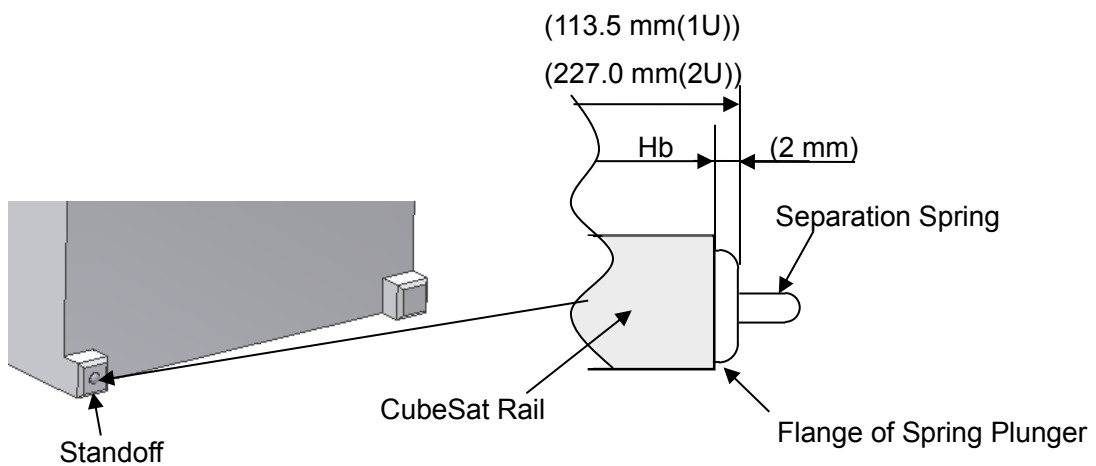

Figure C3-5 Detailed Mounting Position of Spring Plunger/Deployment Switch on Standoff



※Refer to Figure C3-1 for Hb

Figure C3-6 Flange of Spring Plunger Firmly Attached to Standoff Surface

C3.5. Separation switch

- (1) A CubeSat shall have deployment switches (separation switches) on its standoffs as shown in Figure C3-4 to prevent activation in an E-SSOD. For the number of deployment switches to be installed, refer to Section C4.1. The allowable mounting positions are shown in Figure C3-4 and the Detailed mounting position is shown in Figure C3-5.
- (2) CubeSats need to remain inactive while any one of the deployment switches is kept depressed to a maximum distance of 0.75 mm from the standoff surface as shown in Figure C3-7.
- (3) Battery charging, if needed, shall be conducted with all deployment switches being depressed.
- (4) The stroke of a deployment switch shall be 2.0 mm or less from the standoff surface as shown in Figure C3-7.
- (5) The force generated by each deployment switch shall be no greater than 3 N.

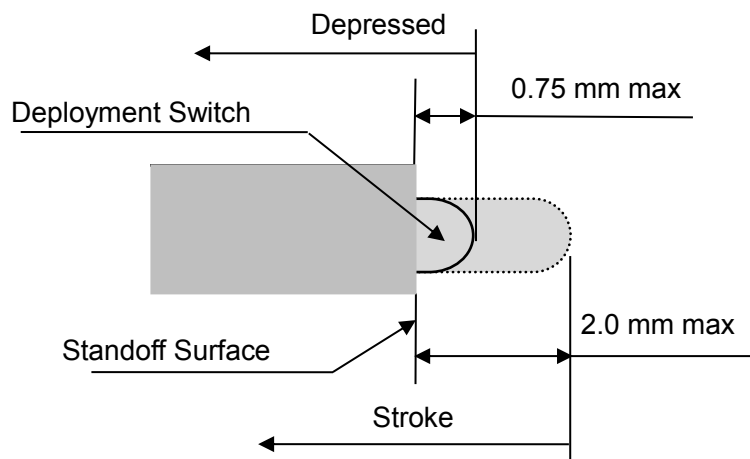

Figure C3-7 Maximum Distance and Stroke of Deployment Switch

C3.6. Access Window

- (1) A CubeSat installed in an E-SSOD can be only accessible through the $+X_{ES}$ ($=+X_{sc}$) axis side as shown in Figure C3-8.
- (2) Any device needs to be accessed after the installation shall be located in the area near access windows.
- (3) Access through a PLF is not available.

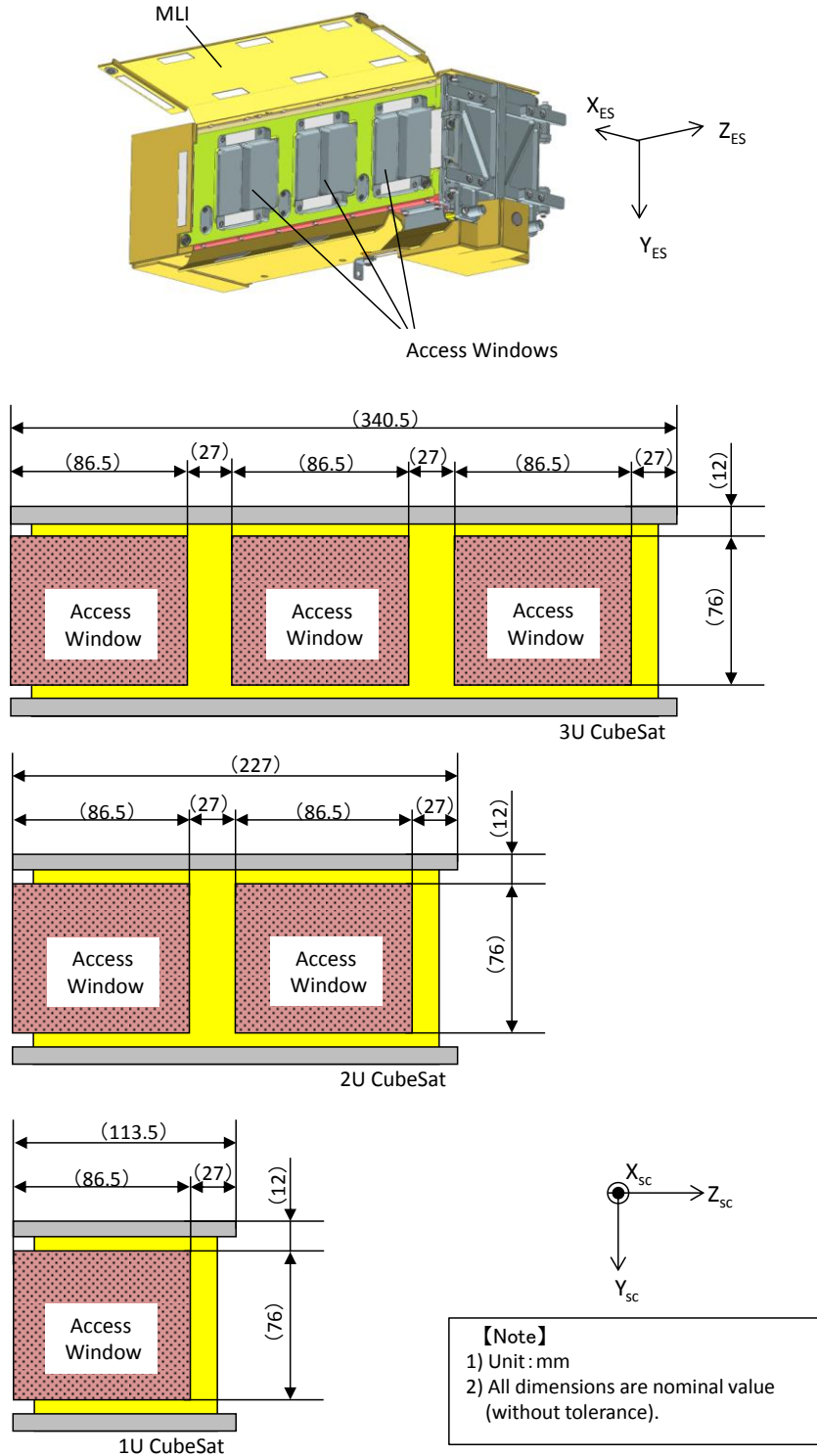

Figure C3-8 Normal Positions of Access Windows

C4. Electrical Interface

C4.1. Deployment Switch and Software

A CubeSat shall have at least three inhibits, deployment switches and RBF pins (Remove before Flight Pins), to prevent unintentional activation in an E-SSOD by on-board batteries or solar cells. Typical circuits are shown in Figure C4-1.

Refer to Chapter C3 for the mechanical interface of the deployment switch.

CubeSats need to remain inactive while any one of the deployment switches is depressed.

In addition, if all development switches are released but one of them is pressed again within 200 s, its timer shall be reset so that the CubeSat can remain inactive. This is to prevent inadvertent activation while CubeSats are being installed in an E-SSOD.

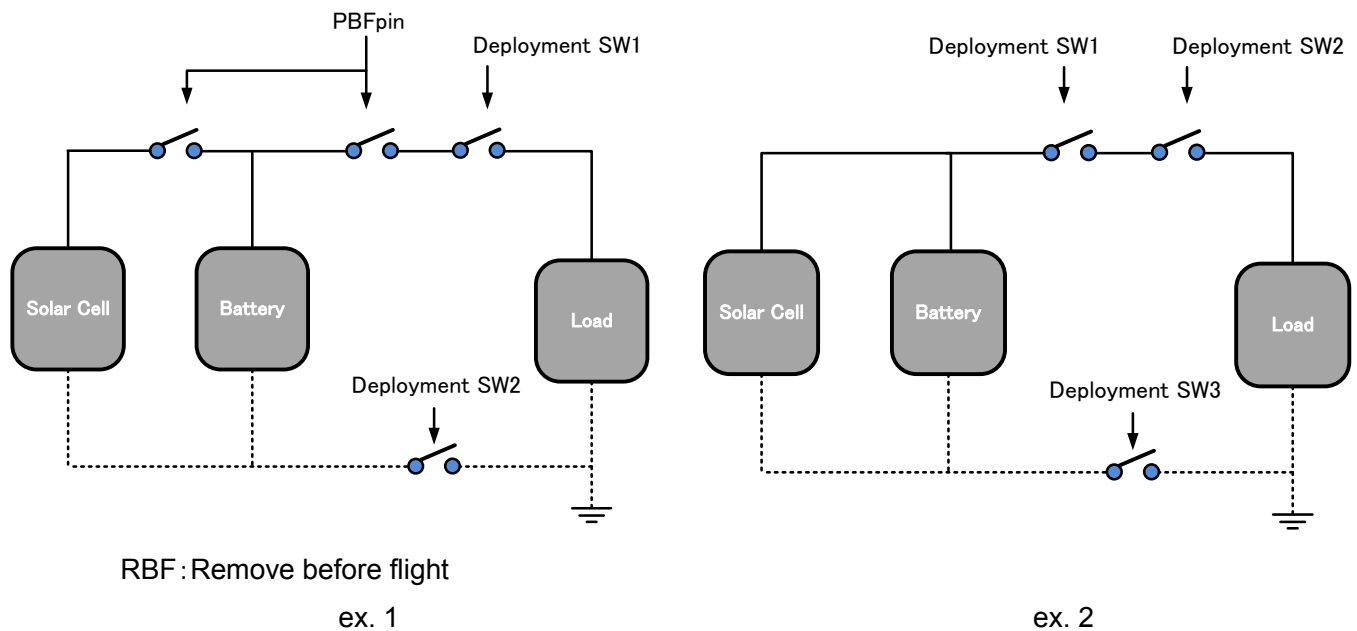

Figure C4-1 Typical circuits with Deployment switches and PBF pins

C4.2. Bonding

A CubeSat shall have a bonding interface on the side of access windows (Figure C3-8) in case access is required after the installation in an E-SSOD.

C5. Tools for CubeSat Verification Test

C5.1. Vibration Test Case

A vibration test case simulating an E-SSOD as shown in Figure C5-1 is used for the vibration test of a CubeSat. When multiple CubeSats are mounted in a single E-SSOD, such CubeSats are recommended to carry out the test using the mass dummy attached to the vibration test case.

Part Number	Name	Note
113C122012-1	VIB TEST CASE 3U	For 3U
113C122012-2	VIB TEST CASE 2U	For 2U
113C122012-3	VIB TEST CASE 1U	For 1U

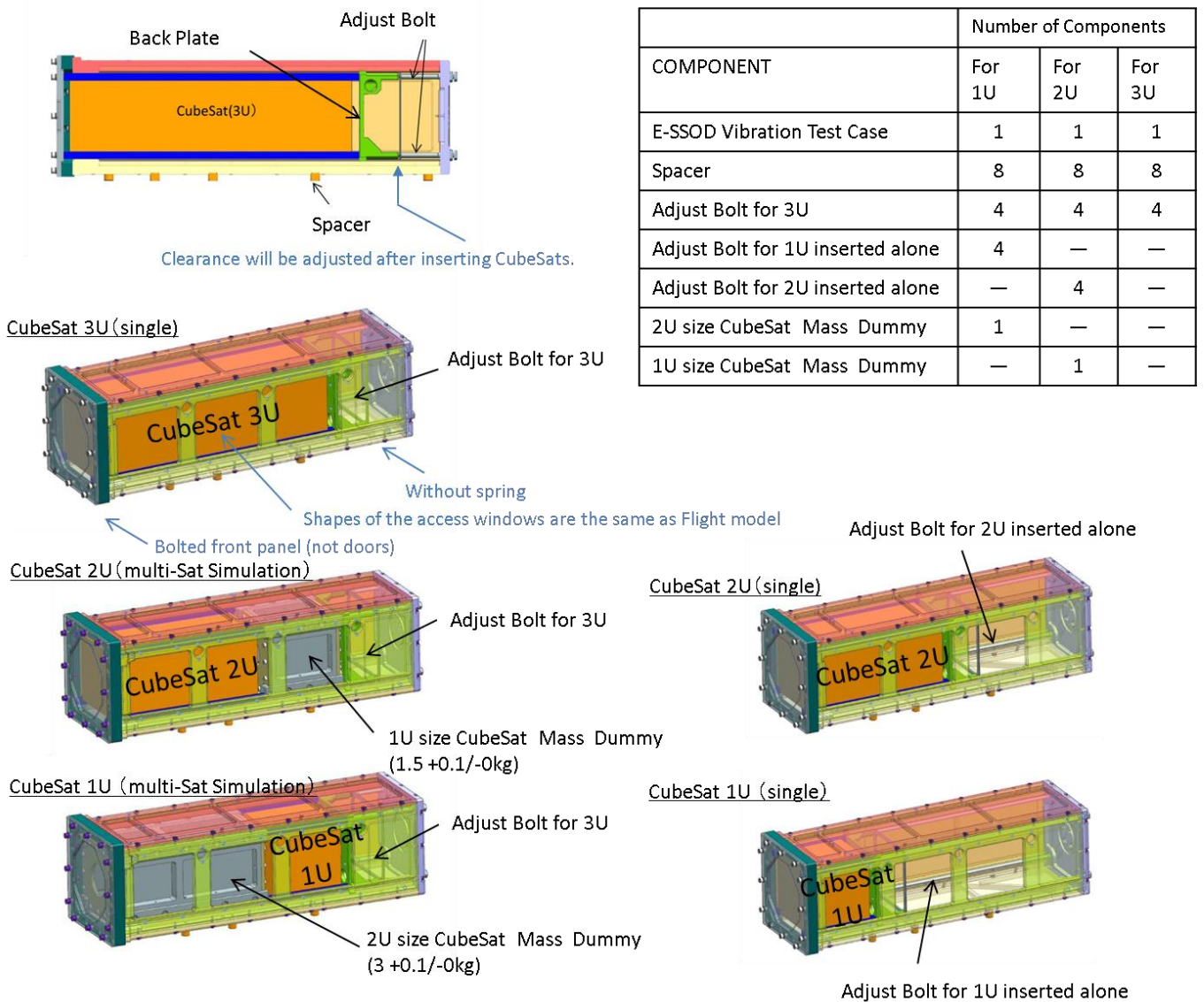

Figure C5-1 Vibration Test Case

C5.2. Fit-check Case

A fit-check case shown in Figure C5-2 is used for fit-check between a CubeSat and an E-SSOD. Its internal dimensions are 100.2 ± 0.1 mm in height and width while those of the E-SSOD are 100.5 ± 0.2 mm.

Part Number	Name	Note
113C122011-1	FITCHECK CASE	For All Sizes (common)

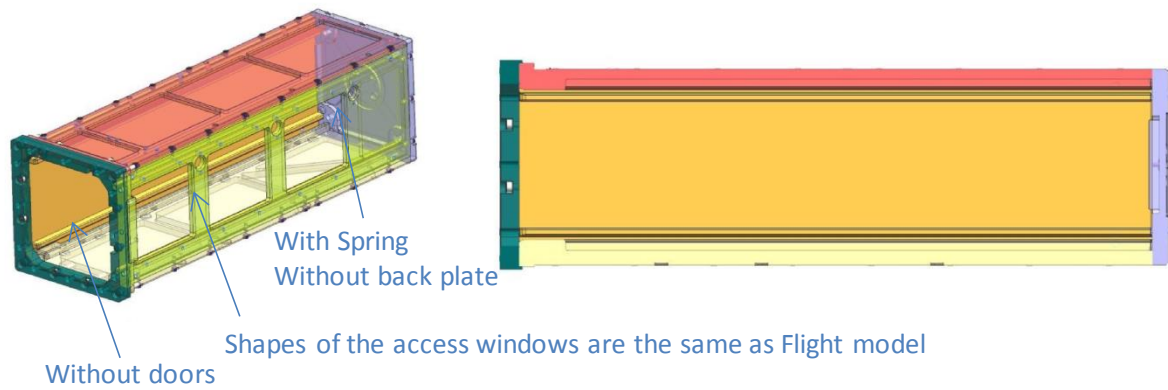

Figure C5-2 Fit Check Case